

Building a Pugmill.

Roger Graham, April 2003
rogergraham@optusnet.com.au

Pugmills come in a variety of sizes and flavours. Basically, they all contain some kind of “auger”, rotating slowly inside a barrel. The auger has blades arranged in a spiral pattern along a stiff strong shaft, so that it chops and pushes the clay along inside the barrel.

At the input end of the barrel is some kind of hopper where you can feed in lumps of clay to be squashed and kneaded. At the other end, the barrel tapers suddenly so the exit hole is smaller, about half the area of the main barrel. Clay emerges from this end in a long cylinder, squashed smoothly together as it comes out the smaller hole, and more-or-less ready to use.

Top-of-the-range machines have a fairly long barrel divided into two parts, with an extra chamber half way along between the “entry” end and the “exit” end. An airtight lid fits closely on this chamber, and a pipe leads off to a vacuum pump which runs all the time when the machine is in use. The idea is to suck out as much air as possible from the clay as it passes along the barrel, to give a denser bubble-free product. You pay more (a LOT more) for one of these de-airing machines.

A pugmill without the vacuum chamber is called a “non-de-airing” machine. More like a Volkswagen than a Cadillac, but not to be despised. The home-made ones described below have pugged many tonnes of clay, and look like lasting for ever.

So... what’s inside one? Here is a picture of the smallest (3 inch) machine made by Venco You’ll notice the large hopper at one end, with a plunger to push the clay down into it.



The barrel in this model is made of cast aluminium alloy, and can be separated into two halves by removing little bolts along its length. The inside diameter is 110 millimetres, and the exit diameter 75 mm.

The next picture shows the same machine with the top half of the barrel removed.

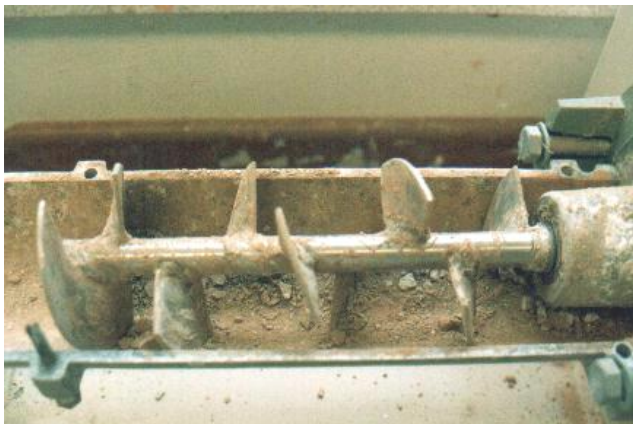

You’ll notice the blades arranged in a spiral pattern along the shaft. The spiral in this case has a right-hand twist. Seen from the exit end, the shaft would have to rotate clockwise. If you are designing your own machine, this is something to keep in mind. Left-handed spiral or right-handed? It depends on the motor and drive you select.

In this view you can see how the exit end of the Venco barrel tapers to a smaller diameter. Also notice the shapes of the blades on the auger. There are seven small blades, postage-stamp size, along the length of the shaft. But at the end nearest the exit, the last two blades are different. Bigger, and shaped like a semi-circle, overlapping in the way that engineers would call a “twin start” thread.

These two larger blades have a slower pitch (less twist) than the little blades behind them. The idea is that the chopped-up clay will pile up behind these larger blades, to then be slowly forced down the taper and well squashed together.



If you set out to make your own pugmill, you have to make a decision about the materials to use.

- Ordinary mild steel is available and cheap, but expect some trouble with rust.
- Cast aluminium alloy seemed like a good idea in the first mill I made, but internal corrosion in the barrel was such a problem that a year later the machine had to be rebuilt.
- Stainless steel is strongly recommended. Not much different to weld, and not expensive if you can obtain scrap offcuts of pipe or sheet.

Two Home-Made Pugmills.



This picture shows one version of a home-made pugmill, at present used for terracotta clay. The barrel is made from stainless pipe as you can see. The feed hopper on this model was made from the same circular pipe as the barrel, an idea that seemed right at the time. But in a later version, you'll notice the hopper is nearly square. Square is better. Easier to feed in big chunks of clay cut from a fresh block.



Here it is again, viewed from the other side, with the cover removed: Under the cover in this model there is a 50-to-1 reduction gearbox obtained from a scrap yard, and a ¼ horsepower motor from an old washing machine. There's a 3 inch pulley on the motor, and a similar pulley on the reduction box, joined by an A-section vee belt. The motor spins at 1425 rpm (Australia, 50 hertz supply) so the auger rotates at $(1425/50) = \text{approx } 30 \text{ rpm}$. This is really a bit slow, but that's how it was left, and it works very well.

In this picture there's a later model. This is the one that began with aluminium alloy castings, and had to be rebuilt by reason of corrosion. The original speed reduction was retained, with a shaft speed of about 40 rpm. The barrel and the hopper and the tapered end were remade using stainless steel., and the original auger altered a bit to fit the different diameter of stainless pipe. The hopper this time was made bigger, and rectangular in shape. Much easier to feed.

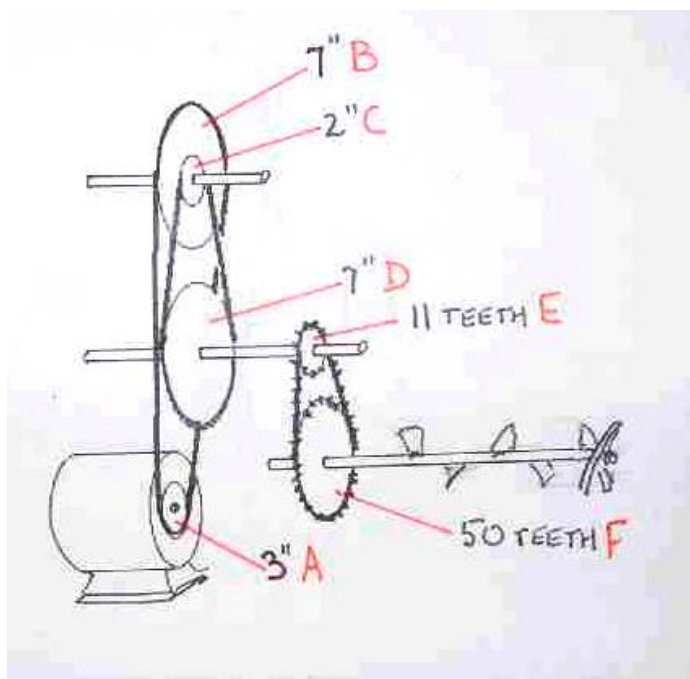

The speed reduction in this model was done using vee belts and pulleys, then a chain and sprocket drive to the auger. Pulley A on the motor (3 inch) drives pulley B (7 inch) on a layshaft. Then C drives D, on a second layshaft which also carries a toothed sprocket E (11 teeth)

On the auger shaft, there's a 50-tooth sprocket from a motor cycle back wheel, driven by chain from sprocket E. If all this seems a bit complicated, well, it is. There's no escape. You have to come up with some ingenious way of achieving the necessary speed reduction, while keeping sufficient strength in the final drive to the auger.

The chain-and-sprocket approach has a lot to recommend it. Old motor cycle parts are easy to come by, and the chain doesn't require the same tension adjustments that vee belts demand. The layshaft carrying D and E can be mounted in a fixed position, and adjustment provided only for the position of the top layshaft and the motor, for belt tensioning.

The Venco machine pictured earlier uses just vee belts and pulleys, That model has a very small pulley (less than 2 inches, I think) on the motor shaft, driving a pulley of about 8 inch size on a layshaft. This layshaft carries a second pulley, double-grooved, about 2 inch size, with two A-section belts driving the final large pulley (about 8 inches again) on the auger. Anything less than the double-belt drive on a big pulley is likely to fail under load.

What Kind of Motor?

A motor as small as a quarter of a horsepower (about 200 watts) is enough for a machine of this size. Bigger would be better, up to say ½ horsepower, but it isn't critical. What **is** important however, is to choose the right kind of motor.



This photo shows two motors salvaged from old washing machines. The one on the left, with the extra cylindrical thing stuck on the top, is a “capacitor start” motor. It has the useful property of developing a high torque from a standing start. In other words, it’s designed to start under load, which is what you want in a pugmill.

The motor on the right (without the capacitor) looks much the same, but isn’t designed to start under load. Once it gets up to speed it runs the same as the other kind, but isn’t really suitable for this job. Switched on with the pugmill full of clay, the motor may be unable to get up speed, and gets hotter and hotter until it burns out.

Clockwise or AntiClockwise?

It doesn’t matter, really. You can make the auger with the blades arranged in a left-hand spiral, or a right-hand spiral. But whichever one you choose, the auger has to rotate so it pushes the clay along towards the exit. You can usually rearrange the wiring in an electric motor to reverse its direction, but if this is a problem you’d better plan ahead and make the spiral on the auger to match the direction of the motor.

Designing the Auger.

It’s too early for that yet. You have to make the auger to fit the barrel. So we’ll design the barrel first.

Making the Barrel: How Big?

The choice of barrel diameter depends on the size of stainless tube available. I was able to get two sizes, 99 mm and 65 mm. The ratio of the cross-section areas of the two needs to be approx 2 to 1. For the tube I obtained, the ratio was (99×99) divided by (65×65) which is about 1.74 to 1. Near enough.

For the tapered portion between the big barrel and the smaller exit pipe, you might be lucky and obtain a stainless offcut of tapered pipe

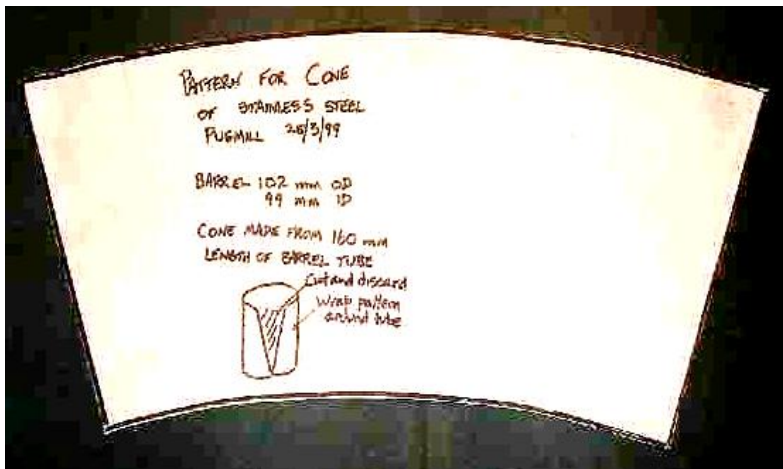

If not, you can make it yourself. In my case, a paper template of the necessary shape was made up, then a 160 mm length of the larger pipe was slit along one edge and opened out a little. With the paper template wrapped around the pipe, the pipe was marked then cut away where necessary.

Rolling the stainless sheet into a cone is not so easy. In my case, I turned a tapered plug from hard wood, just the right size, and used it as a mandrel to support the pipe while it was hammered smoothly into shape. Then the edges were welded where they met, and the weld was ground smooth from the inside using a small abrasive stone in an electric drill. Finally, a

bit more panel-beating and trimming so the tapered portion fitted accurately against the two sizes of pipe.

Now comes a tricky bit. When you come to weld the tapered cone onto the big pipe, you can't just prop one against the other and weld all the way around. The pipe will distort as you heat it, and it's important to keep the barrel truly circular. You really need some kind of restraint to keep the pipe in shape, and a way of tacking the two parts together a little at a time to keep them that shape while the main weld is applied.

This picture shows one way to go about it. The two white circular things are disks of strong particle board, with a central hole which is a tight fit around the large stainless pipe. A disk is forced over the end of the pipe, then the tapered piece is positioned in place ready to weld. Now look at the perforated metal strap. It's just the right length to go once around the pipe where the two parts meet, with a little bolt to pull the two ends together.



With the metal strap in place and the bolt pulled up tight, you can apply a little tack of electric weld through one of the holes, say on the North side. Now go to the South side and apply another tack. Then again on the East, and again on the West. Give the pipe a little time to cool between tacks. With enough tacks in place, you can remove the strap and make a complete weld all around the joint. Followed of course by careful grinding from within, once more using an abrasive wheel in an electric drill.

The Hopper.

Whatever shape you make it, circular or rectangular, you'll need some kind of plunger to push the clay down inside. It needs to be deep enough so you aren't likely to poke fingers down and get caught by the auger. The photos above should give some ideas. If it helps, here's a photo of the original sketches made long ago when repairing the Venco machine that started all this. The plunger in this case was welded rigidly to the end of a short shaft, which in turn was welded rigidly to a longer arm, at the point C on the sketch.

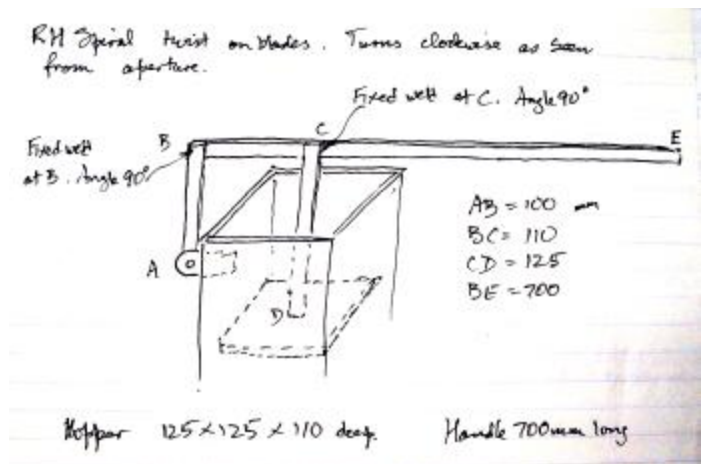

The left end of the long handle was welded rigidly to a further short bar, descending to the only hinged joint in the whole construction, at A (lower left of sketch). One would think that the descending plunger would bind against the hopper wall, but there was enough clearance for it to move. I chose to make mine with a closer fit between plunger and hopper, but this required

a hinged joint between handle and plunger. Not moon rocket science this, but you need to think about it.

Joining the Barrel onto the Rest of the Machine.

Obviously, you need to be able to remove the barrel to get at the auger for maintenance some day. The plate which forms the left hand end of the hopper is made of 3 mm stainless steel, and it has a hole the same size as the barrel. Holes at the corners of the big flat plate are for bolts with wing nuts, easily removed when needed. A matching piece of stainless plate on the main body of the machine has a small central hole through which the auger shaft protrudes.

The Auger, and Bearings on the Auger Shaft.

The auger shaft needs to be made of straight strong stainless steel rod. A suggested size would be 20 mm diameter (about $\frac{3}{4}$ of an inch), and about 400 mm long. Approx 280 mm of this length protrudes inside the barrel, and the remaining 120 mm is inside the drive housing. This length inside the housing is necessary, for the two bearings there have to be some distance apart so the shaft is sufficiently rigid. The distant end of the shaft, away from the bearings, must run true and not be allowed to wander.



One of the two bearings is close against the hopper wall. A good choice here is an ordinary self-aligning ball race, mounted with the usual two short bolts to a suitable angle iron member on the chassis which you design. The other bearing, at the extreme end of the shaft, **must** be a thrust bearing. When the machine is running, the auger exerts a huge force pushing the clay through the nozzle. And in turn, the shaft is pushed back against the bearings by the opposite force. A clutch throw-out bearing from an auto engine, available from a junk yard, is just right for this job.

It surely helps to have the use of a lathe to turn the necessary step on the end of the auger shaft so it plugs into the centre of the thrust race, or to make some kind of adapter bush if needed. And it helps if you have a small centre hole drilled in each end of the shaft, to support it between centres when grinding the blades to shape. More on this later.

Making the Auger.

You need seven small blades, and two larger ones. Just how big, depends on the diameter of the pipe you have for the barrel. Plan for a clearance of about 3 mm between the blades and the wall. This photo shows the templates made for a barrel of internal diameter 89 mm. Not hard to scale up or down for a different diameter.

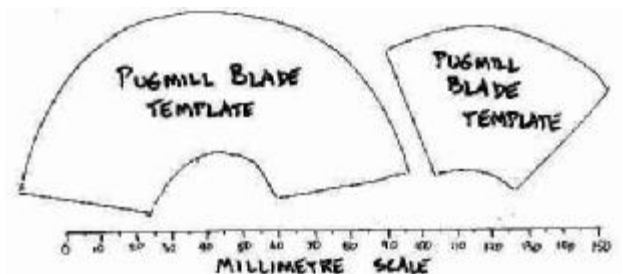

Stainless steel plate 3 mm thick is about right. The blades can be made a millimetre or two oversize if it helps, and trimmed back to size with an angle grinder later.

The two big semi-circular blades have to be twisted to the required spiral shape. Harry Davis gives a detailed description of doing this (pages 152 and 154) in his “Potters Alternative” textbook. It involves gripping one end of the blade in a vice while you twist the other end, after due thought about which way to bend it (left or right hand spiral) and how much bend to give. We’ll assume you have this all worked out, so the blades can be welded to the end of the shaft.

Deciding the correct position for all of the small blades requires a bit of thought. Let’s agree to number the small blades from 1 to 7, starting at the hopper end. Number 1 blade has to be positioned close against the end wall of the hopper, so it just clears the wall. This photo shows the idea. It’s a bit hard to see for the smears of clay, but the leading edge of the blade almost scrapes against the end wall.



Now... where to position the other 6 small blades?

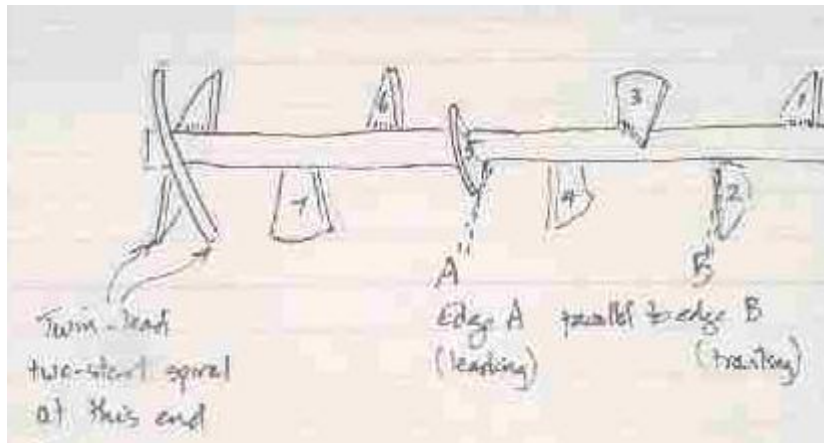

This photo shows one of the long-ago sketches made when building the first pugmill. Blades 1 to 7 resemble a continuous single spiral of pitch approx 150 mm, with alternate sections removed. One revolution of the spiral occupies about 150 mm.

Blades 1 and 6 are in similar positions. Blades 2 and 7 are in similar positions.

Measure the distance from A to B. Divide this length into 7 equal sections. Mark the shaft with a felt pen. Now wind a string in a spiral around the shaft, starting at A.

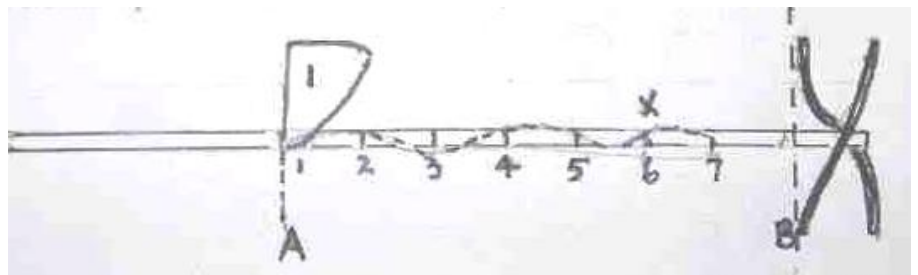

Make 2 turns between A and X so blade **6** will fit on the shaft in the same position as blade 1. Trace this spiral onto the shaft with a felt pen. The intersections of the spiral path and the circular bands 2 to 7 give the contact points of blades 2 to 7

When you come to weld the small blades to the shaft, you need some kind of jig to hold each one in place. Harry Davis suggests using little blocks of wood cut obliquely at one end, to lie snugly against the shaft while the new blade is held against the sloping end. Try tacking all the blades in place, and giving the whole set a final inspection before completing the welds.

The newly welded set of blades is unlikely to fit snugly into the barrel, and will need to be trimmed accurately to a cylindrical outline. The next photo shows one way to do this. The thick block of wood is a few millimetres longer than the auger shaft. The two upstanding pieces of chipboard at the ends carry pointed screws which are used to support the shaft “between centres” using the two little central holes which you thoughtfully provided when originally making it. The whole assembly is clamped securely in a vice, and the auger is rotated slowly while you hold an angle grinder in a suitable position. Trim the blades so the auger slides easily into the barrel, with a little clearance (say 3 mm) all around.



In this picture you can see the auger assembled in the main chassis. Notice the thrust bearing at the left end of the auger shaft, and the 50-tooth sprocket which drives the shaft. This big sprocket is mounted on a steel bush with a wide flange, specially made for the job. The bush is held onto the shaft by a 6 mm drive-in “Sellock” pin through a hole in the shaft



Here is the barrel assembly, ready to bolt onto the main chassis. Note the four bolt holes near the corners of the square plate, and the smaller holes around the top flange to fix the hopper in place.



The hopper is a simple folded box made up from lighter gauge stainless sheet., fixed to the main barrel with six small bolts. The rusty stains are from these bolts, sold as “stainless” but they corroded anyway.



Unless the finished pugmill is used almost every day, its contents are likely to dry out. You can delay this by providing a plastic cap over the delivery end, as in this picture.



To close off the hopper and keep it damp when not in use, try a block of soft foam plastic trimmed to shape, and glued to a thin wooden cap. Just wet the plastic, squeeze it out, and insert the block in the hopper with the wood on top as a lid. Rest the plunger on the lid to keep it all in place. This photo shows two of these, one for the pugmill with the circular hopper, and the other for the rectangular one.